

# Instruction manual

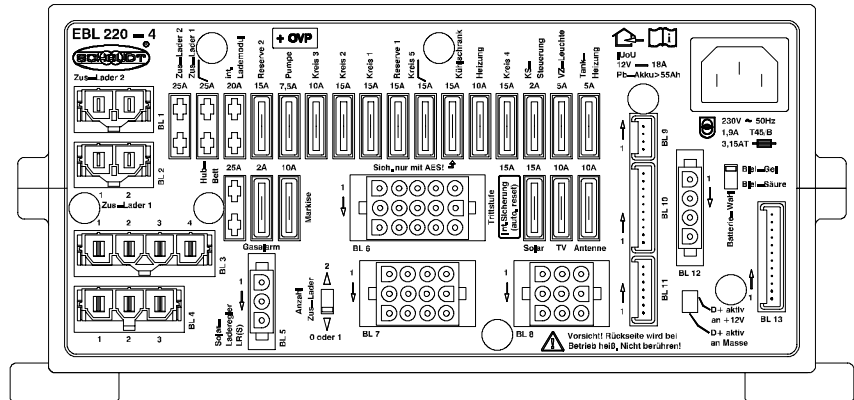

## Electroblock **EBL 220-4** **EBL 220-4 with OVP**

### Table of contents

1	Safety Information	2
1.1	Meaning of safety symbols	2
1.2	General safety information	2
2	Introduction	3
3	Operation	3
3.1	Starting the system	3
3.2	Changing the battery	4
3.3	Operating faults	5
3.4	Shutting down the system	7
3.5	Closing down the system	7
4	Application and function	9
4.1	Battery functions	10
4.2	Additional functions	11
5	Maintenance	12
	Appendix	13

## 1 Safety Information

### 1.1 Meaning of safety symbols



**▲ DANGER!**

Failure to heed this warning may result in death or serious injury.



**▲ WARNING!**

Failure to heed this warning may result in personal injuries.



**▲ ATTENTION!**

Failure to heed this warning may result in damage to the device or connected consumers.

### 1.2 General safety information

The device is state-of-the-art and complies with approved safety regulations. Nonetheless, personal injuries or damage to the device may occur if the safety instructions contained herein are not followed.

Ensure that the device is in perfect working order before use.

Any technical faults which may have an adverse effect on personal safety or device safety must be rectified immediately by qualified personnel.



**▲ DANGER!**

230 V mains voltage carrying parts.

Danger of death due to electric shock or fire:

- Do not carry out maintenance or repair work on the device.
- If cables or the device housing are damaged, no longer use the device and isolate from the power supply.
- Ensure that no liquids enter the device.



**▲ WARNING!**

Hot components!

Burns:

- Only replace blown fuses when the device is completely de-energised.
- Only replace blown fuses once the cause of the fault has been identified and rectified.
- Never bypass or repair fuses.
- Only use original fuses rated as specified on the device.
- Device parts can become hot during operation. Do not touch.
- Never store heat sensitive objects close to the device (e.g. temperature sensitive clothes if the device has been installed in a wardrobe).

## 2 Introduction



▲ This device is exclusively designed for installation into a vehicle.

This instruction manual contains important information for the safe operation of equipment supplied by Schaudt. It is imperative that you read and follow this safety information.

The instruction manual should always be kept in the vehicle. All safety information must be passed on to other users.



▲ This device is not intended to be used by persons (including children) with limited physical, sensory or mental aptitude or lack of experience and/or knowledge unless they are supervised by a person responsible for their safety or have received instruction from this person as to how the device is used.

Children are to be supervised so as to ensure they do not play with the device.

## 3 Operation

The Electroblock is operated solely from the DT/LT ... control and switch panel connected to it and via the ST ... control panel (if fitted).

The EBL 220 with OVP Electroblock does not require daily operation.

Initial setting is only needed after the type of battery (lead-acid or lead-gel) has been changed or during commissioning or when upgrading with accessories (see Chapter 3.2 and installation instructions for details).

### 3.1 Starting the system



#### ▲ ATTENTION!

Electroblock can be set up incorrectly!

The connected devices will be damaged. Therefore prior to starting:

- Make sure the living area battery is connected.
- You must ensure that the battery selector switch (Fig. 3, Pos. 11) is set to the correct position for the type of battery being used.
- You must ensure that the AES fuse (Fig. 3, Pos. 6) is only inserted if an AES refrigerator is connected to the system. Otherwise, the living area battery may get totally discharged. Battery damage is possible.
- You must ensure that the switch for the number of auxiliary chargers (Fig. 3, Pos. 18) is set in the correct position.

**12 V main switch  
(on DT/LT ... control and  
switch panel)**

- Deactivate battery isolation on the DT/LT ... control and switch panel (see instruction manual for the associated control and switch panel).
- After deactivating the battery isolation or after changing batteries: Turn on the 12 V main switch on the DT/LT ... control and switch panel briefly to start up the consumers.

The 12 V main switch (see the instruction manual for the associated control and switch panel) switches all consumers and the control and switch panel on and off.

Exceptions:

- Frost protection valve
- Heater
- Step
- Gas alarm/waste water valve
- Power circuit 4
- Waste-water tank heating
- Fold-away bed
- Awning light
- Awning
- Aerial
- AES/compressor refrigerator
- Fridge controller

For more information, see the DT/LT ... control and switch panel instruction manual.

### Step switch



#### ▲ ATTENTION!

The self-resetting fuse can trip!

Overcurrent cut-out:

- Only press the step switch briefly.
- Wait approx. 1 minute before pressing the step switch again so that the fuse can reset itself.

### Solar charger operation



#### ▲ ATTENTION!

Battery buffer function missing!

The connected devices will be damaged:

- Never run the solar charger without a battery being connected.

## 3.2 Changing the battery



#### ▲ ATTENTION!

Wrong battery type or incorrectly connected battery!

Will damage the battery or the devices connected up to the Electroblock:

- Batteries shall only be changed by qualified personnel.
- Follow the instructions of the battery manufacturer.
- The Electroblock is to be used solely for connecting the 12 V power supply to 6-cell lead-gel or lead-acid batteries. Never use unapproved types of battery (e.g. NiMH batteries).



▲ Only batteries of the same type and capacity should normally be used, i.e. same as those installed by the manufacturer.

▲ You can change over from lead-acid to lead-gel batteries. You cannot change over from lead-gel to lead-acid batteries! Your vehicle manufacturer will provide you with information about this.

- Changing the battery**
- Disconnect the battery from the Electroblock by activating the battery isolation on the DT/LT ... control and switch panel on (see Chapter 3.5 as well).
  - Replace the battery.
  - Check once more to ensure that you have fitted the correct type of battery afterwards.



**▲ DANGER!**

Battery selector switch set incorrectly!  
 Danger of explosion caused by the build up of oxyhydrogen gas.

- Set the battery selector switch to the correct position.



**▲ ATTENTION!**

Battery selector switch set incorrectly!  
 The battery will be damaged.

- Set the battery selector switch to the correct position.
- Disconnect the Electroblock from the mains before resetting the battery selector switch.

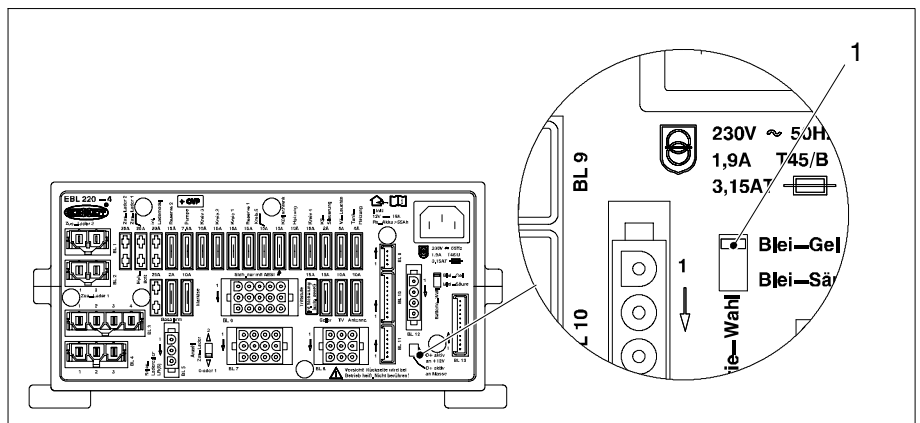

Fig. 1 Battery selector switch

- Move the battery selector switch (Fig. 1, Pos. 1) into the relevant position using a thin object (e. g. ball-point pen):
  - Lead-gel battery: Set the battery selector switch to “Lead-gel” (Gel).
  - Lead-acid battery: Set the battery selector switch to “Lead-acid” (Säure).

**Starting up the system**

- Start the system as instructed in Chapter 3.1.

**3.3 Operating faults**

**Flat vehicle fuses**

The majority of power supply system faults are caused by blown fuses.

**Self-resetting fuses**

The following functions are protected by a self-resetting fuse:

- the “Step“ output

If a fault occurs here, the step must not be operated for approx. 1 min. These fuses reset themselves automatically within this period.

The following functions are protected by self-resetting fuses too:

- Current measurement
- Illumination control and switch panel
- Main Switch

When faults expected in these functions, disconnect the electroblock completely from 12 V for approx. 1 min (best: disconnecting the battery poles).

Please contact our customer service address if you cannot eliminate the fault using the following table.

If this is not possible, e.g. if you are abroad, you can have the Electroblock repaired at a specialist workshop. In this case you must ensure that the warranty is not invalidated by incorrect repairs being carried out and Schaudt GmbH will not accept any liability for damage resulting from such repairs.

**Emergency operation**

If a fault has been caused by a defective DT/LT ... control and switch panel it is always possible to run emergency power via the emergency plug. This is attached to the instruction manual.

<b>Fault</b>	<b>Possible causes</b>	<b>Remedy</b>
Living area battery is not charged during 230 V operation (battery voltage permanently below 13.3 V)	No mains voltage	Switch the cut-out in the vehicle back on; check the mains voltage
	Defective Electroblock	Call customer service
Living area battery over-loaded during 230 V operation (battery voltage permanently above 14.5 V)	Defective Electroblock	Call customer service
Starter battery is not charged during 230 V operation (battery voltage permanently below 13.0 V)	No mains voltage	Switch the cut-out in the vehicle back on; check the mains voltage
	Defective Electroblock	Call customer service
Living area battery is not charged whilst driving (battery voltage below 13.0 V)*	Defective alternator	Have the alternator checked
	No voltage at D+ input	Have the fuse and wiring checked
	Defective Electroblock	Call customer service
Living area battery is over-loaded whilst driving (battery voltage permanently above 14.3 V)	Defective alternator	Have the alternator checked
The fridge does not work whilst driving*	No power supply to the fridge	Have the fuse and wiring checked
	Defective Electroblock	Call customer service
	Defective fridge	Have the fridge checked
Solar charger does not work (power supply and engine are off)*	Solar charger not plugged in	Plug the solar charger in
	Defective fuse or wiring	Have the fuse and wiring checked
	Defective solar charger	Have the solar charger checked

Fault	Possible causes	Remedy
12 V power supply in the living area does not work	12 V main switch for living area battery is switched off	12 V main switch for living area battery must be switched on
	Activate the battery isolation on the DT/LT ... control and switch panel	Deactivate the battery isolation on the DT/LT ... control and switch panel
	Defective fuse or wiring	Have the fuse and wiring checked
	Defective Electroblock	Call customer service
The Electroblock cannot be operated from the DT/LT ... control and switch panel	Defective Electroblock	Call customer service
	Defective DT/LT ... control and switch panel	Disconnect the BL. 10/BL. 13 plug from the Electroblock and plug in the emergency plug. Have the DT/LT ... control and switch panel repaired.



- ▲ If the device becomes too hot due to excessive ambient temperature or lack of ventilation, the charging current is automatically reduced. However, always prevent the device from overheating.
- ▲ If the automatic shutdown mechanism of the battery monitor is triggered, fully charge up the living area battery.
- ▲ \* For faults regarding the D+-signal, the position of the D+-switch (see Fig. 3, Pos. 13) has to be checked. Ask your dealer, if required.

### 3.4 Shutting down the system

- Activate the battery isolation on the DT/LT ... control and switch panel (see instruction manual for the associated control and switch panel).



- ▲ The heater system's frost protection valve opens when the living area battery is isolated from the Electroblock by the battery isolation. The boiler and the water tank are emptied when the frost protection valve is opened. For more information, see the instruction manual of the heater system.

### 3.5 Closing down the system



#### ▲ **ATTENTION!**

Total discharge!

Damages the living area battery:

- The living area battery must be fully charged before closing down and before restarting the system. (Vehicle with an 80 Ah battery must be connected to the mains supply for at least 12 hours and a 160 Ah battery for up to 24 hours.)



**▲ ATTENTION!**

Permitted input voltage exceeded!

Will damage the consumers connected to the system:

- Never run a solar charger supplied by Schaudt without a battery being connected to the system.
- Unplug the “+ solar-cell” connector on the solar charger first if the battery is going to be changed or removed.

**Closing down for up to 6 months**

- The living area battery must be fully charged before closing the system down.

The living area battery is then protected against total discharge. This applies only if the battery is intact. Follow the instructions of the battery manufacturer. The shut down system requires approx. 4 Ah a month.

**Disconnecting the living area battery from the 12 V mains supply**

Disconnect the living area battery from the 12 V power supply if you are not going to use the motorhome for a lengthy period (i.e. during the winter). The system is equipped with a battery isolator that completely isolates the living area battery (electrically) from the vehicle. Battery isolation is activated from the DT/LT ... control and switch panel (see DT/LT control and switch panel instruction manual).

- 12 V main switch on the DT/LT ... control and switch panel must be switched off.
- Activate battery isolation on the DT/LT ... control and switch panel.
- Pull out the fuse for the AES refrigerator.



- ▲ The living area battery can also be charged using the internal charger module, an auxiliary battery charging unit, the solar charger and the alternator when the battery isolation is activated.

**Closing down for more than 6 months**

- The living area battery must be fully charged before closing the system down.
- Remove the clamps from the battery terminals.
- Remove the “+ solar-cell” connector on the solar charger.



- ▲ The battery alarm is no longer active.



## 4 Application and function

The Elektroblock EBL 220-4 and EBL 220-4 with OVP is the central power supply unit for all 12 V consumers connected to the electrical system of the motorhome or caravan. It is normally fitted inside a cabinet or a stowage space and can be accessed from the front to change a fuse.

### Overvoltage protection OVP

The electroblock EBL 220-4 with OVP is suitable for all cases of application in which the danger of overvoltage is especially large. This can e. g. be lightning strikes in the public mains, generator operation, bad electronic installations or trips to foreign countries.

For this in the electroblock an overvoltage protection is fitted in internally between the mains connection and the loading module.

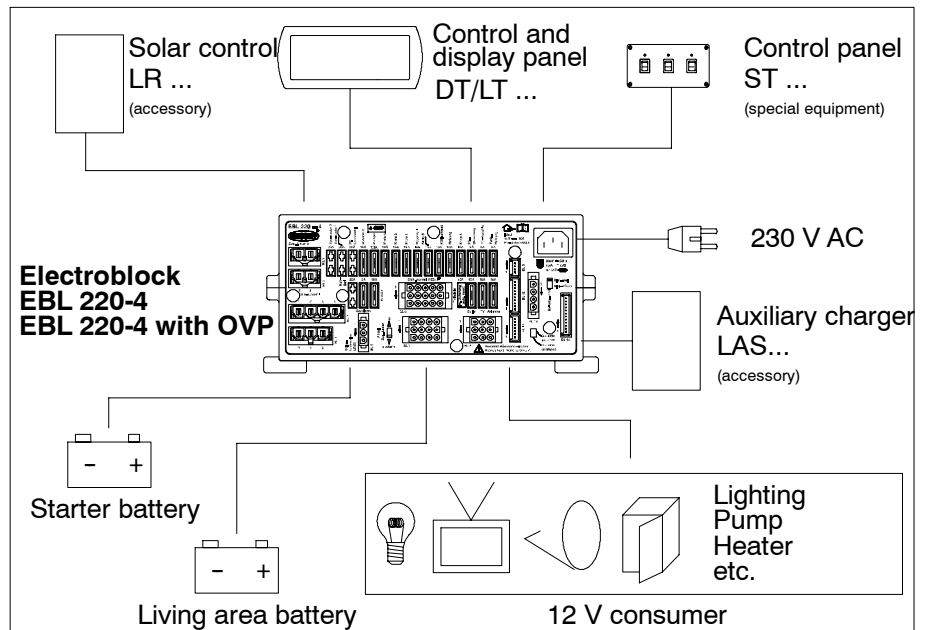

Fig. 2 Onboard power supply system

### Modules

The Elektroblock EBL 220-4 consists of:

- A charging module for recharging all of the connected batteries
- The complete 12 V distribution system
- The fuses for the 12 V power circuits
- A battery monitor module
- Other control and monitoring functions

In addition the Elektroblock EBL 220-4 with OVP consists:

- Overvoltage protection OVP, disconnecting the electroblock in case of detecting an overvoltage of the 230 V supply.

### System devices

A DT ... or LT ... control and switch panel must be connected up to run it. For additional functions an ST ... switch panel (optionally) can be connected. These devices control the electrical functions in the motorhome's living area as well as the accessories.

Connection options are available for up to two additional battery charging units and a solar charger.

Flat vehicle fuses are used to protect the various circuits. The only exceptions are the step and the frost protection valve

- Protective circuits**
- Overtemperature
  - Overload
  - Short circuit

**Mains connection** 230 V AC voltage  $\pm 10\%$ , 47 – 63 Hz sinewave, protection class I

**Current-carrying capacity** 12 V outputs shall only be loaded up to a maximum of 90 % of the rated current of the associated fuse (see installation instructions or front plate).

## 4.1 Battery functions

**Suitable batteries** 6-cell lead-acid or lead-gel batteries from 55 Ah upwards

**Battery charging whilst driving** Simultaneous starter battery and living area battery charging via alternator, parallel battery switching via an isolation relay

**Battery isolation** Battery isolation (activated from the DT/LT ... control and switch panel) cuts off the following connections from the living area battery:

- All 12 V consumers
- The frost protection valve

This prevents the living area battery from being slowly discharged by closed-circuit current whilst closing down the vehicle.

The batteries can still be charged using the Electroblock, the alternator, an auxiliary charging unit or the solar charger, even when the battery isolation is activated.

**Battery selector switch** The switching option provided by the battery selector switch ensures optimum charging of the two different types of battery, lead-acid and lead-gel.

**Battery monitor with automatic disconnection** The battery monitor of the control and switch panel DT/LT ... with dynamic voltage wave continuously monitors the living area battery. It switches off "earlier" with small discharge currents than with large ones. This enhances the total discharge protection. Monitoring also occurs when the device is switched off. Depending on the current consumption, a warning message is displayed once the value falls below 12 V.

If the living area battery voltage continues to drop and falls below 10.5 V, the battery monitor immediately switches off each 12 V consumer. The control and switch panel also switch off automatically. Only the anti-freeze valve is still supplied with current to ensure that it remains closed. Prior to shutdown, all the switching states and the battery capacity value are stored and restored after switching on.

If an overload or an insufficiently charged living area battery causes the voltage to fall so low that the automatic disconnection is triggered, any consumers which are not essential should be switched off.

You may be able to switch on again the 12 V power supply for a short time under certain circumstances. In this case you must switch on the 12 V main switch on the DT/LT ... control and switch panel.

However, you cannot switch the 12 V power supply back on if the battery voltage remains below 11.0 V.

Fully charge up the living area battery as soon as possible. For more information, see the "Battery voltages" description in the associated DT/LT ... control and switch panel instruction manual.

**Closed-circuit current coming from living area battery**

When using a DT/LT ... control and switch panel: approx. 20 mA; 12.6 V battery voltage after being disconnected from the mains for 10 minutes; battery isolation is not activated; control and switch panel illumination and main switch are switched off.

**Battery charging from mains connection**

**Living area battery**

Charging curve	IUoU
Final charging voltage	14.3 V
Charging current	18 A
Trickle charge voltage	13.8 V with automatic switching

**Starter battery**

Maximum charging current (trickle charge)	6 A
---	-----



▲ This device is exclusively designed for installation into a vehicle.

**4.2 Additional functions**

**Automatic switch function for AES/compressor refrigerator**

This relay supplies the AES/compressor refrigerator with power from the starter battery when the vehicle engine is running and the D+ connection is live. An AES/compressor refrigerator is powered by the living area battery when the vehicle engine is switched off.

**Mains charging Starter battery**

This feature provides an automatic trickle charge for the starter battery up to a 6 A maximum when the 230 V mains is connected to the Electroblock.

**Step fuse**

The "Step" output is protected with a self-resetting fuse.

If there is a fault, e.g. overcurrent, the self-resetting fuse will disconnect the relevant circuit.

This fuse resets automatically approx. 1 minute after the fault has been rectified.

The circuit is protected with a 15 A fuse.

**Battery charging via solar charger**

Maximum permitted charging current 14 A, protected by a 15 A fuse  
Either the living area battery or the living area battery and the starter battery will be charged, depending on the type of the solar charger being used.

**Fold-away bed, awning, gas alarm, waste water valve and awning light** The power supply to these consumers will be disconnected automatically as soon as the engine is running (the D+ connection supplies the voltage in this case). The awning light can also be used if the 12 V power supply is switched off.

**Tank heating** The tank heating is switched on from the DT/LT ... control and switch panel.

**D+switching** The input D+ can be adapted to the D+ of the vehicle:

- D+ vehicle: active high
- D+ vehicle: active low

The adjustment is correctly ex works.

**Switch panel ST ...** The switch panel ST ... is an optional extension for the electroblock EBL 220. Via three buttons consumers can be switched off individually.

If the switch panel ST ... is not available, a strapping plug must be connected to block BL11 of the electroblock EBL 220 (also see block diagram, appendix F).

## **5 Maintenance**

The electroblock requires no maintenance.

**Cleaning** Clean the Electroblock using a soft, moist cloth and mild detergent. Never use spirit, thinners or similar substances. Do not allow fluid to ingress the Electroblock.

© The reproduction, translation and duplication of this manual, even in parts, is not allowed without written authorisation.

## Appendix

### A EU Conformity Declaration

Schaudt GmbH hereby confirms that the Electroblocks EBL 220-4 and EBL 220-4 with OVP design complies with the following relevant regulations:

- RICHTLINIE 2006/95/EG DES EUROPÄISCHEN PARLAMENTS UND DES RATES vom 12.12.2006 zur Angleichung der Rechtsvorschriften der Mitgliedstaaten betreffend elektrische Betriebsmittel zur Verwendung innerhalb bestimmter Spannungsgrenzen
- RICHTLINIE DER KOMMISSION 2004/104/EG vom 14. Oktober 2004 zur Anpassung der Richtlinie 72/245/EWG des Rates über die Funkentstörung (elektromagnetische Verträglichkeit) von Kraftfahrzeugen an den technischen Fortschritt
- RICHTLINIE 2005/49/EG DER KOMMISSION vom 25. Juli 2005 zur Änderung der Richtlinie 72/245/EWG des Rates über die Funkentstörung (elektromagnetische Verträglichkeit) von Kraftfahrzeugen und der Richtlinie 70/156/EWG des Rates zur Angleichung der Rechtsvorschriften der Mitgliedstaaten über die Betriebserlaubnis für Kraftfahrzeuge und Kraftfahrzeuganhänger zwecks Anpassung an den technischen Fortschritt
- RICHTLINIE 2005/83/EG DER KOMMISSION vom 23. November 2005 zur Änderung der Anhänge I, VI, VII, VIII, IX und X der Richtlinie 72/245/EWG des Rates über die Funkentstörung (elektromagnetische Verträglichkeit) von Kraftfahrzeugen zwecks ihrer Anpassung an den technischen Fortschritt
- RICHTLINIE 2004/108/EG DES EUROPÄISCHEN PARLAMENTS UND DES RATES vom 15.12.2004 zur Angleichung der Rechtsvorschriften der Mitgliedstaaten über die elektromagnetische Verträglichkeit und zur Aufhebung der Richtlinie 89/336/EWG
- Gesetz über die elektromagnetische Verträglichkeit von Betriebsmitteln (EMVG) vom 26. Februar 2008

The original EU conformity declaration is available and can be referred to at any time. This declaration is based on:

Model approval No.: e1\*72/245\*2009/19\*5664\*01  
EU Approval sign: e1 03 5664

**Manufacturer** Schaudt GmbH, Elektrotechnik & Apparatebau  
**Address** Planckstraße 8  
88677 Markdorf  
Germany

### B Special fittings/Accessories

**Control panel** A DT ... control and display panel or an LT ... LED panel is required to operate the EBL 220 electroblock.

**Switch panel** Schaudt ST ... switch panel (special version for providing full range of functions). Without ST ... switch panel, bridge connector is inserted at BL. 11.

- Auxiliary charging units** Schaudt LAS ... battery charger model with maximum charging current of 18A (two devices can be connected at the same time)  
An additional 2-pin charging cable can be supplied with each device; ask about lengths
- Solar charger** Schaudt solar charger LR ... model for solar modules with a total current of 14 A, including 0.5 m connection cable and connector plug
- Emergency plug** In the event the DT ... control and display panel is defective, the electroblock can continue to be used if the emergency plug is inserted into BL. 10 and BL. 13.

## **C Customer service**

**Customer service address** Schaudt GmbH, Elektrotechnik & Apparatebau  
Planckstraße 8  
88677 Markdorf, Germany

Phone: +49 7544 9577-16 Email: kundendienst@schaudt-gmbh.de

Opening hours Mon to Thur 08:00 – 12:00, 13:00 – 16:00 hours  
Fri 08:00 – 12:00 hours

- Sending in the device** Returning a defective device:
- Always use well-padded packaging.
  - Fill in and enclose the fault report, see Appendix D.
  - Send it to the addressee delivered free.



**E Design**

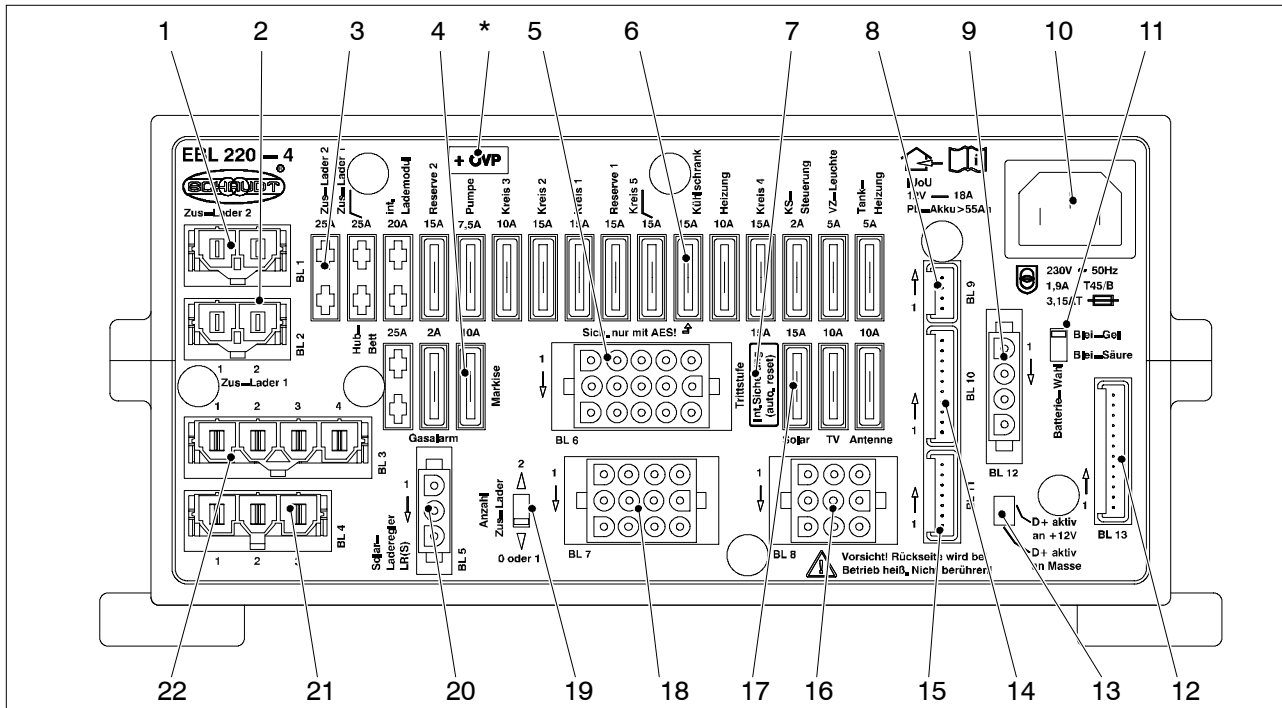

Fig. 3 Electroblock EBL 220-4 and EBL 220-4 with OVP

- |  |  |
|--|--|
| <ul style="list-style-type: none"> <li>1 BL. 1 connections for auxiliary charging unit 2</li> <li>2 BL. 2 connections for auxiliary charging unit 1</li> <li>3 Flat vehicle fuses for charger modules and general consumers</li> <li>4 Flat vehicle fuses for fold-away bed/gas alarm/awning</li> <li>5 BL. 6 connections for heating/pump/reserve</li> <li>6 Flat vehicle fuse for AES/compressor refrigerator</li> <li>7 Self-resetting fuse for step</li> <li>8 BL. 9 connections for solar charger, LRS only</li> <li>9 BL. 12 connections, living area battery sensor, D+</li> <li>10 Mains connection</li> <li>11 Battery selector switch for lead-gel/lead-acid</li> <li>12 BL.13 connections for DT/LT ... control and switch panel</li> <li>13 Switch D+ active high/D+ active low</li> </ul> | <ul style="list-style-type: none"> <li>14 BL. 10 connections for DT/LT ... control and switch panel</li> <li>15 BL. 11 connections for ST ... switch panel or strapping plug</li> <li>16 BL. 8 connections for step, TV, aerial and other consumers</li> <li>17 Flat vehicle fuse for solar, TV, aerial</li> <li>18 BL. 7 connections for fridge controller, awning, tank heating, awning light and other consumers</li> <li>19 Selector switch for the number of auxiliary charging units</li> <li>20 BL. 5 connections, solar charger LR ...</li> <li>21 BL. 4 connections</li> <li>22 BL. 3 connections, supply to fridge, fold-away bed</li> </ul> |
|--|--|
- \* Label "+OVP", only for EBL 220-4 with OVP

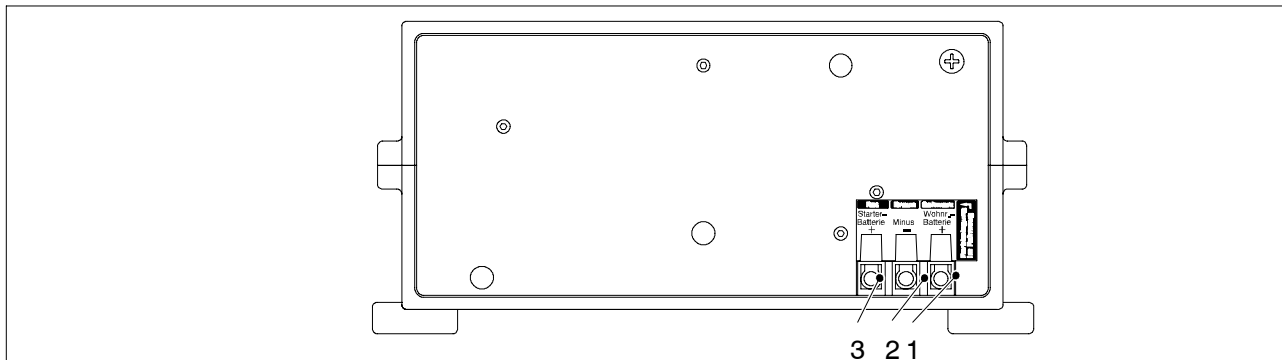
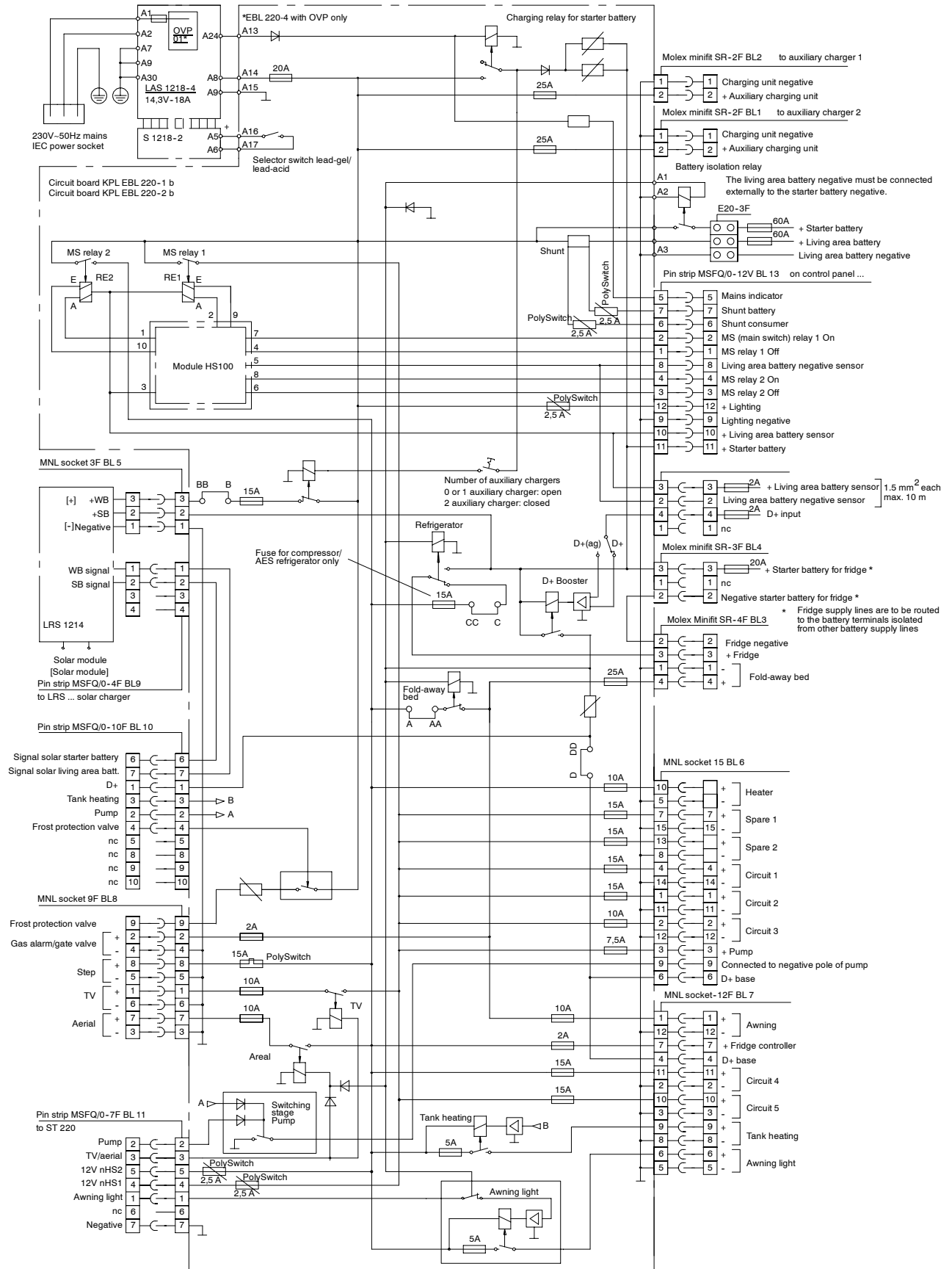

Fig. 4 Structure Elektroblock EBL 220-4 (rear)

- |   |  |
|---|--|
| <ul style="list-style-type: none"> <li>1 Living area battery connection</li> <li>2 Ground connection</li> </ul> | <ul style="list-style-type: none"> <li>3 Starter battery connection</li> </ul> |
|---|--|



### F Block diagram/Connection diagram



(This page intentionally left blank)